

Quiet-Duct Conic-Flow® Silencers

Section 15000 Specifications

1.01 General

- A. Furnish and install "Conic-Flow" (tubular) silencers of the types and sizes shown on the plans and/or listed in the schedule. Silencers shall be the product of IAC Acoustics. Any specification change must be submitted in writing and approved by the Architect/Engineer, in writing, at least 10 days prior to the bid due-date.

2.01 Materials

- A. Outer casings of tubular silencers shall be made of type #G-90 lock-former-quality galvanized steel in the following gauges:

Outside Diamer, In.	Metal Gauge	Outside Diameter, In.	Metal Gauge
12-36	22	38-60	18

- B. Interior construction of tubular silencers shall be compatible with the respective outside casing.
- C. Filler material shall be inorganic glass fiber of a proper density to obtain the specified acoustic performance and be packed under not less than 5% compression to eliminate voids due to vibration and settling. Material shall be inert, vermin- and moisture-proof.
- D. Combustion ratings for the silencer acoustic fill shall be not greater than the following when tested to ASTM E 84, NFPA Standard 255, or UL No. 723:

Flamespread Classification	20
Smoke Development Rating.....	20

3.01 Construction

- A. Units shall be constructed in accordance with the ASHRAE Guide recommendations for high pressure duct work. Seams shall be lock formed and mastic filled. Rectangular casing seams shall be in the corners of the silencer shell to provide maximum unit strength and rigidity. Interior partitions shall be fabricated from single-piece, margin-perforated sheets and shall have die-formed entrance and exit shapes so as to provide the maximum aerodynamic efficiency and minimum self-noise characteristics in the sound attenuator. Blunt noses or squared off partitions will not be accepted.
- B. Interior partitions for tubular silencers shall be secured with galvanized steel radial mounting brackets welded to the partition and the outer casing. The radial brackets shall be installed full length and at 120 degree angles to each other to assure uniform spacing for consistent aerodynamic and acoustic performance.
- C. Sound attenuating units shall not fail structurally when subjected to a differential air pressure of 8 inches water gauge from inside to outside the casing. Airtight construction shall be provided by use of a duct sealing compound on the job-site material and labor furnished by the contractor.

4.01 Acoustic Performance

- A. All silencer ratings shall be determined in a duct-to-reverberant room test facility which provides for airflow in both directions through the test silencer in accordance with ASTM Specification E477-99. The test facility shall be NVLAP accredited for the ASTM E477-99 test standard. Data from a non-accredited laboratory will not be acceptable. The test set-up and procedure shall be such that all effects due to end reflection, directivity, flanking transmission, standing waves and test chamber sound absorption are eliminated.

Acoustic ratings shall include Dynamic Insertion Loss (DIL) and Self-Noise (SN) Power Levels both for FORWARD FLOW (air and noise in same direction) and REVERSE FLOW (air and noise in opposite directions) with airflow of at least 2000 fpm entering face velocity. Data for rectangular and tubular type silencers shall be presented for tests conducted using silencers no smaller than the following cross-sections:

Rectangular, inch: 24 x 24, 24 x 30, or 24 x 36
 Tubular, inch: 12, 24, 36 and 48

5.01 Aerodynamic Performance

- A. Static pressure loss of silencers shall not exceed those listed in the silencer schedule as the airflow indicates. Airflow measurements shall be made in accordance with ASTM specification E477-99 and applicable portions of ASME, AMCA, and ADC airflow test codes. Tests shall be reported on the identical units for which acoustic data is presented.

6.01 Certification

- A. With submittals, the manufacturer shall supply certified test data on Dynamic Insertion Loss, Self-Noise Power Levels, and Aerodynamic Performance for Reverse and Forward Flow test conditions. Test data shall be for a standard product. All rating tests shall be conducted in the same facility, shall utilize the same silencer, and shall be open to inspection upon request from the Architect/Engineer.

7.01 Duct Transitions

- A. When transitions are required to adapt silencer dimensions to connecting duct work they shall be furnished by the installing contractor.

Low Frequency Conic-Flow® Silencers

Type: FCL

Forward & Reverse Flow Ratings

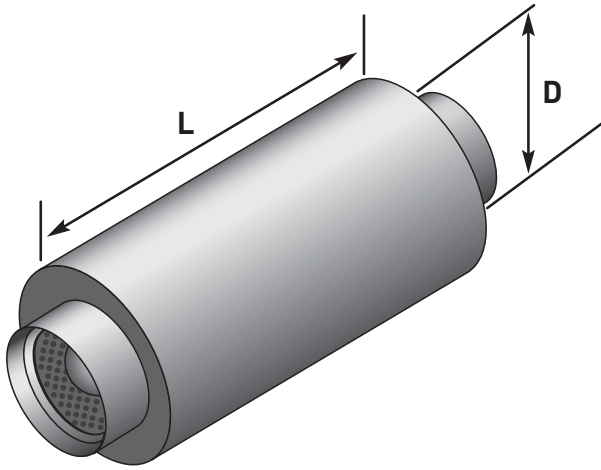

The IAC Type FCL Conic-Flow Silencers have been rated with procedures certified in accordance with applicable portions of ASTM E477. All Dynamic Insertion Loss and Self-Noise Acoustic Performance Data were obtained in a NVLAP accredited Aero-Acoustic Laboratory using the duct-to-room reverberant test facility **with air flowing through the silencers.**

Designating Silencers

Model: 12 FCL 36

Type: FCL **Diameter:** 12" **Length:** 36"

Table I: Dynamic Insertion Loss (DIL) Ratings: Forward (+)/Reverse (-) Flow

IAC Model	Octave Band	1	2	3	4	5	6	7	8
	Hz	63	125	250	500	1K	2K	4K	8K
	Face Velocity, fpm	Dynamic Insertion Loss, dB							
12FCL	-4000	8	17	25	30	35	34	23	18
	-2000	8	16	23	29	34	34	25	19
	0	8	15	22	27	33	31	26	21
	2000	8	14	20	25	32	27	26	23
	4000	7	12	18	23	31	29	27	23
24FCL	-4000	9	16	26	31	35	21	15	12
	-2000	9	15	24	29	33	21	16	13
	0	8	14	23	28	34	23	19	15
	2000	7	13	21	26	34	25	21	16
	4000	6	12	20	24	32	25	21	17
36FCL	-4000	11	20	29	33	30	20	17	12
	-2000	10	19	28	33	29	21	18	13
	0	9	17	26	32	29	23	19	15
	2000	8	15	24	31	29	25	20	16
	4000	7	13	22	30	28	25	20	16
48FCL	-4000	12	22	33	37	30	17	13	11
	-2000	12	20	31	36	30	18	15	13
	0	11	19	29	35	30	20	17	15
	2000	9	17	27	33	29	22	18	16
	4000	9	16	24	32	28	23	18	17
60FCL	-4000	15	26	36	38	29	15	11	10
	-2000	14	24	34	37	29	16	12	11
	0	13	22	33	36	28	19	15	14
	2000	11	20	31	35	27	21	17	16
	4000	10	18	28	35	26	20	17	17

(+) Forward Flow / (-) Reverse Flow. Aero-acoustic performance data based on NVLAP accredited laboratory tests conducted in strict accordance with ASTM E477-99. Contact IAC if attenuation in excess of 50 dB is required.

Table II: Weights & Measures

Model	Duct Diameter, Inches	12	14	16	18	20	22	24	26
	Silencer Length, Inches	36	36	36	36	40	44	48	52
FCL	Weight, lb.	99	111	132	149	168	188	208	234

Model	Duct Diameter, Inches	28	30	32	36	40	44	48	60
	Silencer Length, Inches	56	60	64	72	80	88	96	120
FCL	Weight, lb.	255	374	495	600	746	951	1140	1873

Table III: Aerodynamic Performance

IAC Model	L/Ft	Static Pressure Drop, i.w.g.															
		All Sizes	0.05	0.06	0.07	0.08	0.10	0.11	0.13	0.14	0.16	0.18	0.20	0.22	0.24	0.26	0.29
FCL	All Sizes	0.05	0.06	0.07	0.08	0.10	0.11	0.13	0.14	0.16	0.18	0.20	0.22	0.24	0.26	0.29	0.31
Silencer Face Velocity, fpm		2000	2200	2400	2600	2800	3000	3200	3400	3600	3800	4000	4200	4400	4600	4800	5000

Table IV: Self-Noise Power Levels, dB re: 10-12 Watts

IAC Model	Octave Band	1	2	3	4	5	6	7	8
	Hz	63	125	250	500	1K	2K	4K	8K
	Silencer Face Velocity, fpm								
FCS (all sizes)	-3000	56	56	55	56	55	55	50	45
	-2000	47	47	47	47	45	45	37	29
	-1000	31	32	32	31	30	30	20	20
	1000	39	35	32	32	30	25	20	20
	2000	52	48	46	46	45	42	39	25
	3000	60	56	54	54	53	52	50	40

(+) Forward Flow / (-) Reverse Flow. Aero-acoustic performance data based on NVLAP accredited laboratory tests conducted in strict accordance with ASTM E477-99.

TAKE NOTE!

- Silencer Face Area is the cross-sectional area at the silencer entrance
- Face Velocity is the CFM of airflow divided by the Face Area (in sq. ft.)
- Pressure Drop for any velocity can be calculated from this equation:
 $PD = (Actual\ FV/Catalog\ FV)^2 \times (Catalog\ PD)$
- Self Noise values shown are for a four-square-foot face area silencer
- For each doubling of the face area add 3 dB to the self-noise values listed
- For each halving of the face area subtract 3 dB from the self-noise values listed
- Weights and measures are listed for limited number of available sizes